

MAR901 series Pilot operated

AIR UNIT (R.UNIT)

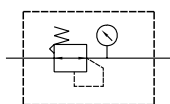

Symbol



- MAR901 can be installed at any point in the compressed air system without regard to accessibility ensuring accurate pressure regulation over a wide range of air flows upto 56640 ℓ /min

Specification

Model	MAR901
Bore No.	50A
Port size	2
Medium	Air
Max. operating pressure	3.1 MPa
Regulated pressure range	Upto 1.75 MPa (with the help of a pilot regulator)
Ambient temperature	0~+80°C (No freezing)
Standard nominal flow rate(*)	59000 ℓ /min
Attachment	Pressure gauge(PG-50)
Weight	3055 g

* Flow is at 1 MPa supply pressure and 0.1 MPa pressure drop of 0.6 MPa of secondary pressure.

Order example

MAR901 – 50A – □

MODEL

BORE SIZE
50A: 2

PORT THREAD
Blank: Rc thread
G: G thread
NPT: NPT thread

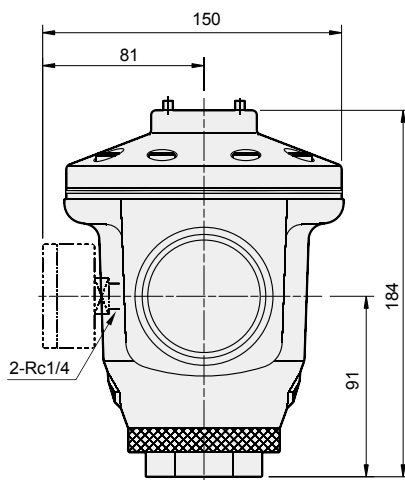
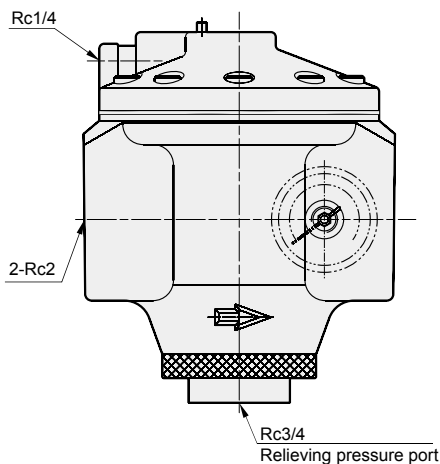
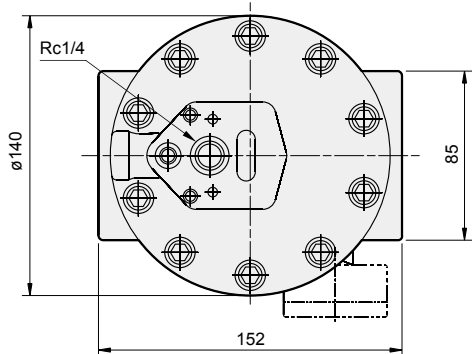

Flow feature

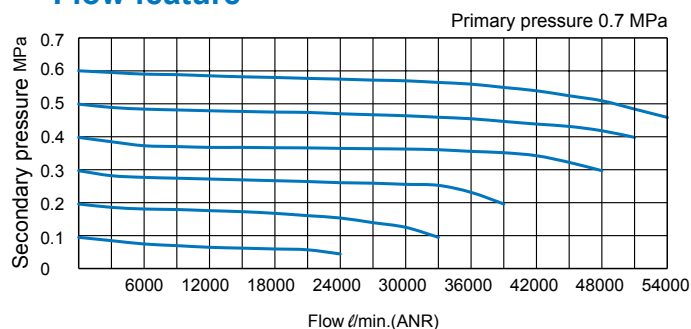

Pilot operation

